

Zonated model of hepatic glucose metabolism

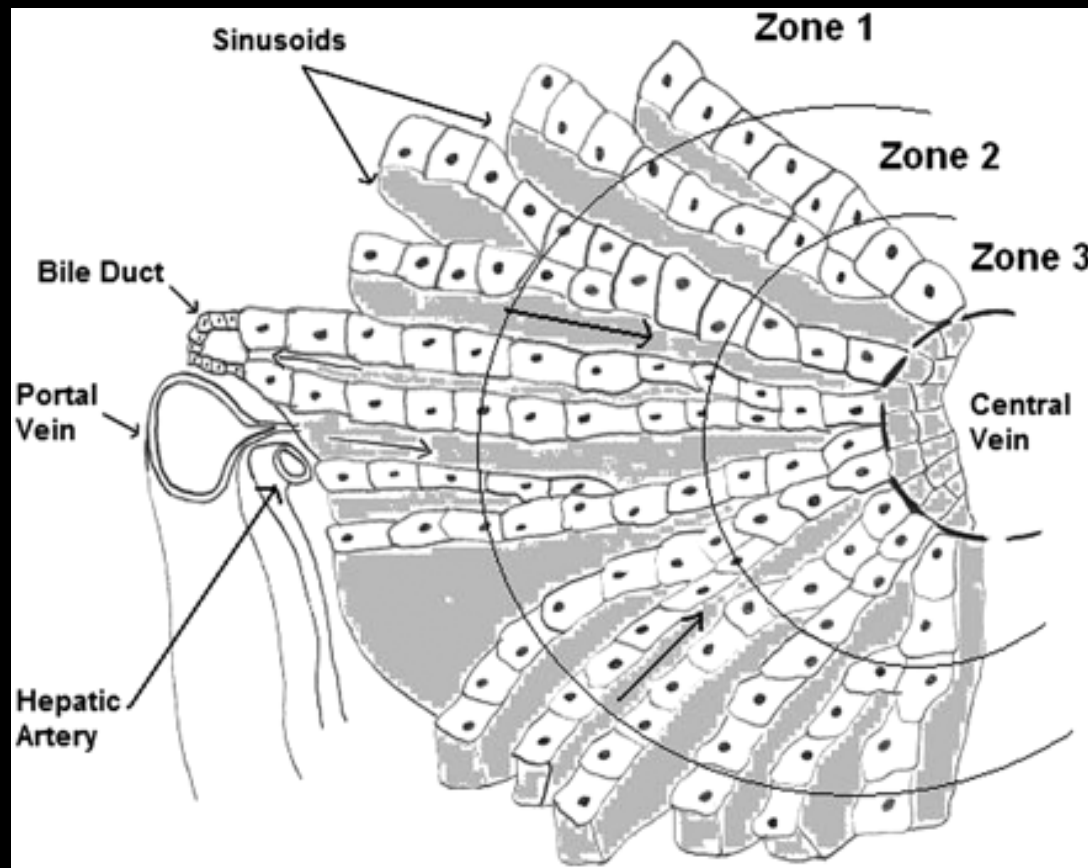

Matthias König
Berlin [11|04|11]
Group seminar

Overview

- Zonation of hepatic glucose metabolism
- Single hepatocyte model of glucose metabolism
- Zonated model of hepatic glucose metabolism

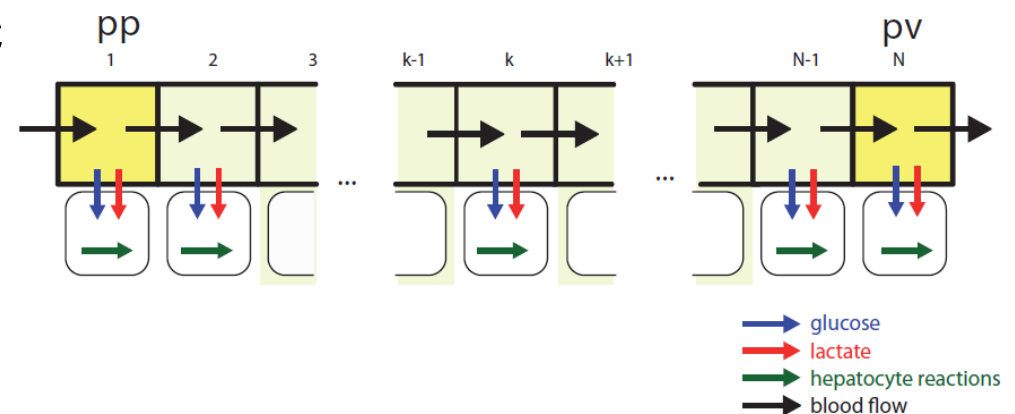
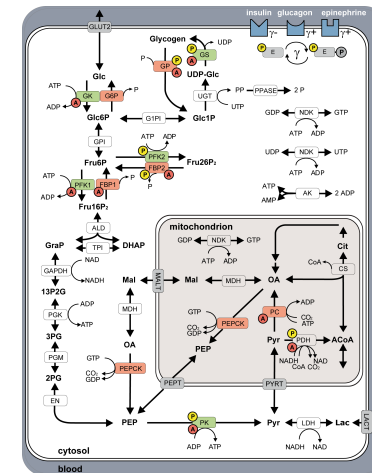
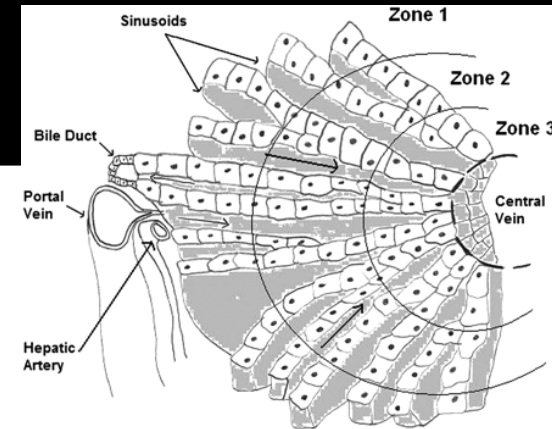

→ glucose
→ lactate
→ hepatocyte reactions
→ blood flow

Liver zonation

- liver highly structured in identical subunits: liver **lobuli**
- **Sinusoid**: structural unit within the lobulus
- Blood flow: periportal (pp) → perivenous (pv)
- Varying hepatocyte metabolism from pp to pv (**zonation**)
 - glucose metabolism
 - nitrogen metabolism
 - fatty acid metabolism
 - detoxification
 - ...

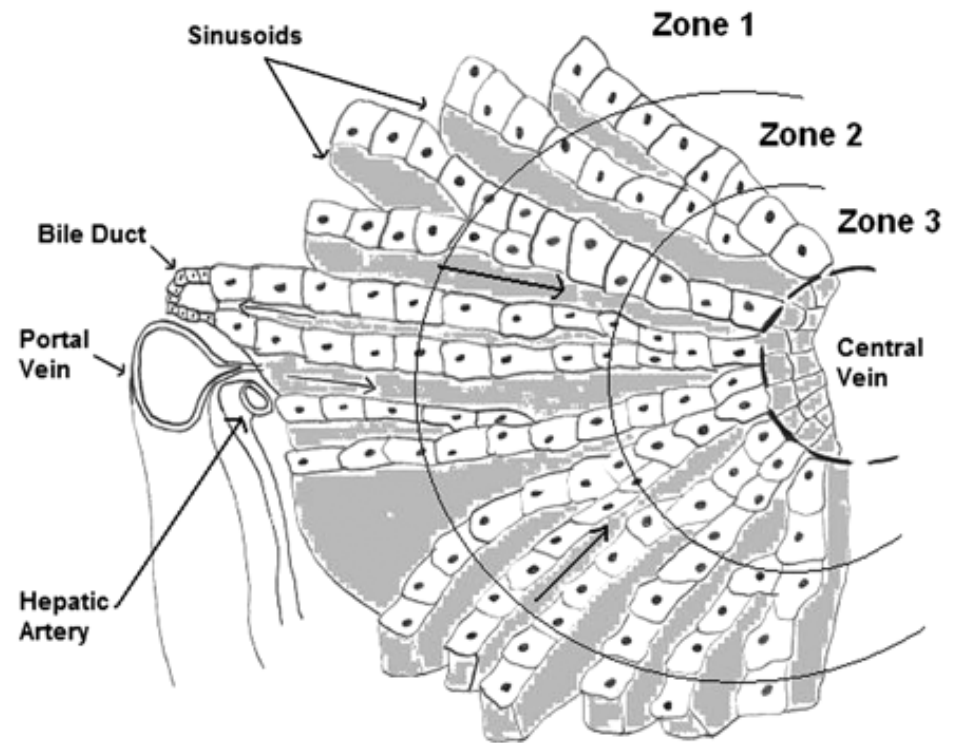

pp → pv gradients

- Nutrient gradients
 - due to production/utilization by hepatocytes (glucose, lactate, oxygen)
 - depending on hepatic metabolism & exchange
- Hormone gradients
 - due to hepatic clearance (insulin, glucagon, epinephrine)

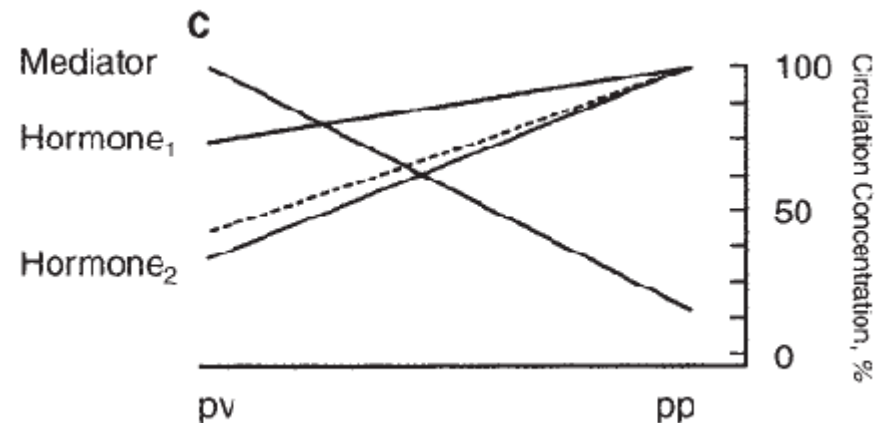
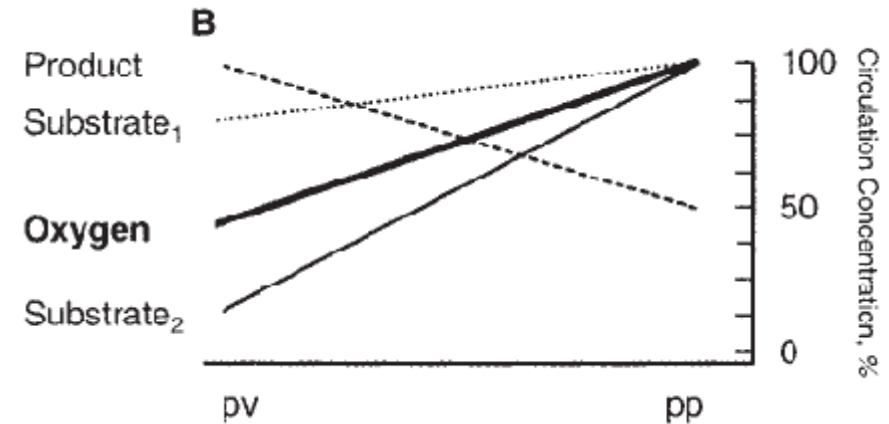

Zonation of glucose metabolism

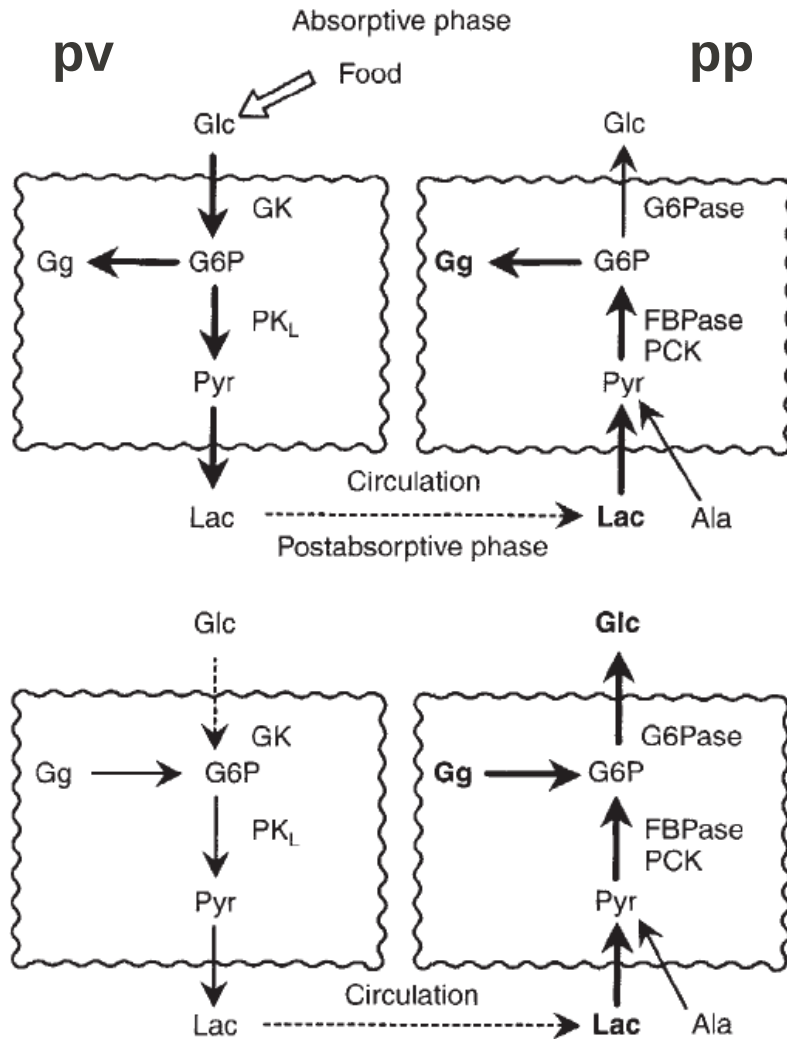
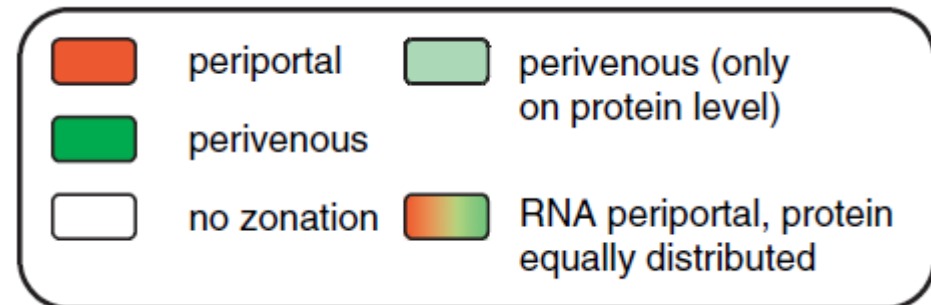
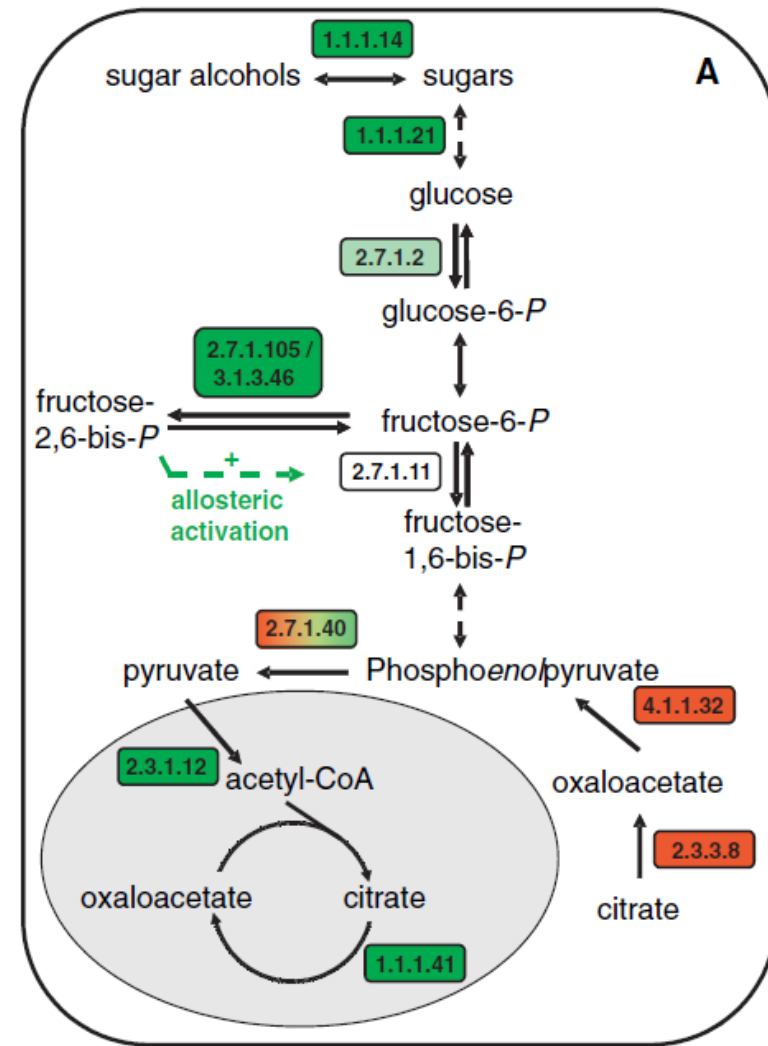
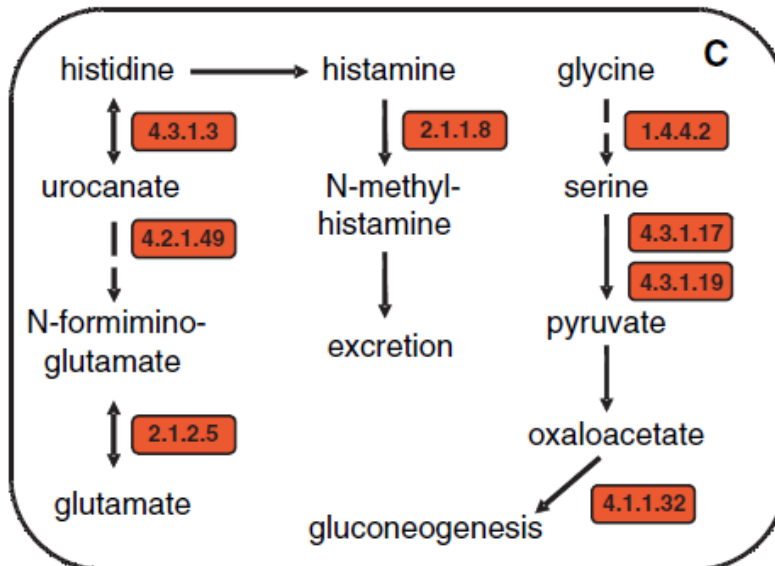

Fig. 4. Zonation of carbohydrate metabolism (metabolic fluxes). Metabolites are: Ala, alanine; G6P, glucose 6-phosphate; Gg, glycogen; Glc, glucose; Lac, lactate; Pyr, pyruvate. Enzymes are shown only in the zones where they are predominantly expressed: FBPase, fructose 1,6-bisphosphatase; G6Pase, glucose 6-phosphatase; GK, glucokinase; PCK, phosphoenolpyruvate carboxykinase; PK_L, pyruvate kinase type L.

- **pp (periportal)**
 - **gluconeogenesis**
 - **glycogen synthesis via indirect pathway (gluconeogenesis)**
- **pv (perivenous)**
 - **glycolysis**
 - **glycogen synthesis via direct pathway (glucose)**
- **HGU and HGP performed simultaneously in different parts of sinusoid**

Zonated proteins

- Zonated expression and protein content of key enzymes of glucose metabolism (PEPCK, GK, ...)
- **pp** → gluconeogenesis
- **pv** → glycolysis



Single hepatocyte

- detailed ODE model
 - glycolysis, gluconeogenesis and glycogen metabolism
 - including insulin, glucagon and epinephrine
- average hepatocyte
 - reproducing mean liver data
 - Simultaneous HGP and HGU only explainable with zoned model

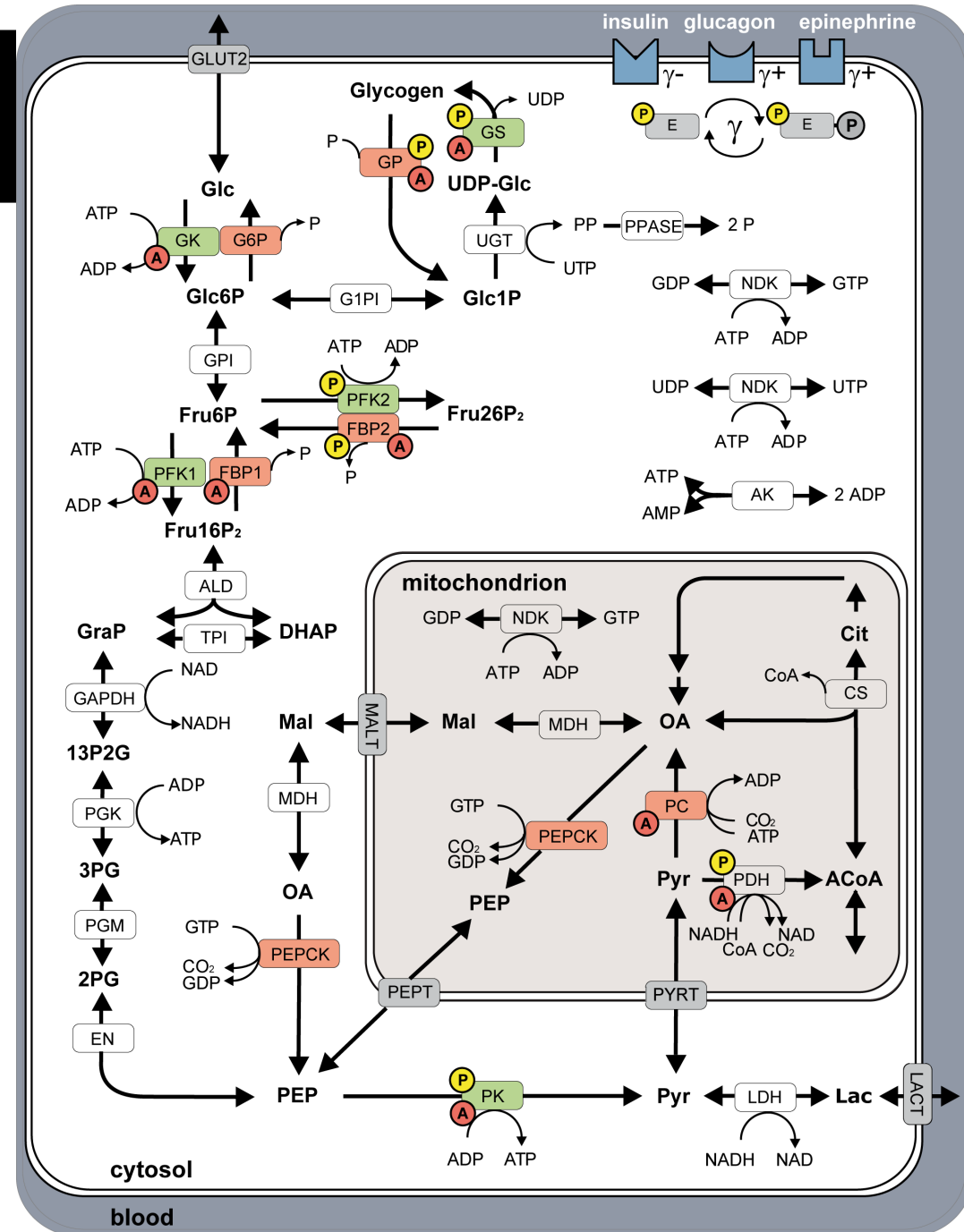

Model: Zonated glucose metabolism

- Incorporation of single hepatocyte model in sinusoid layout

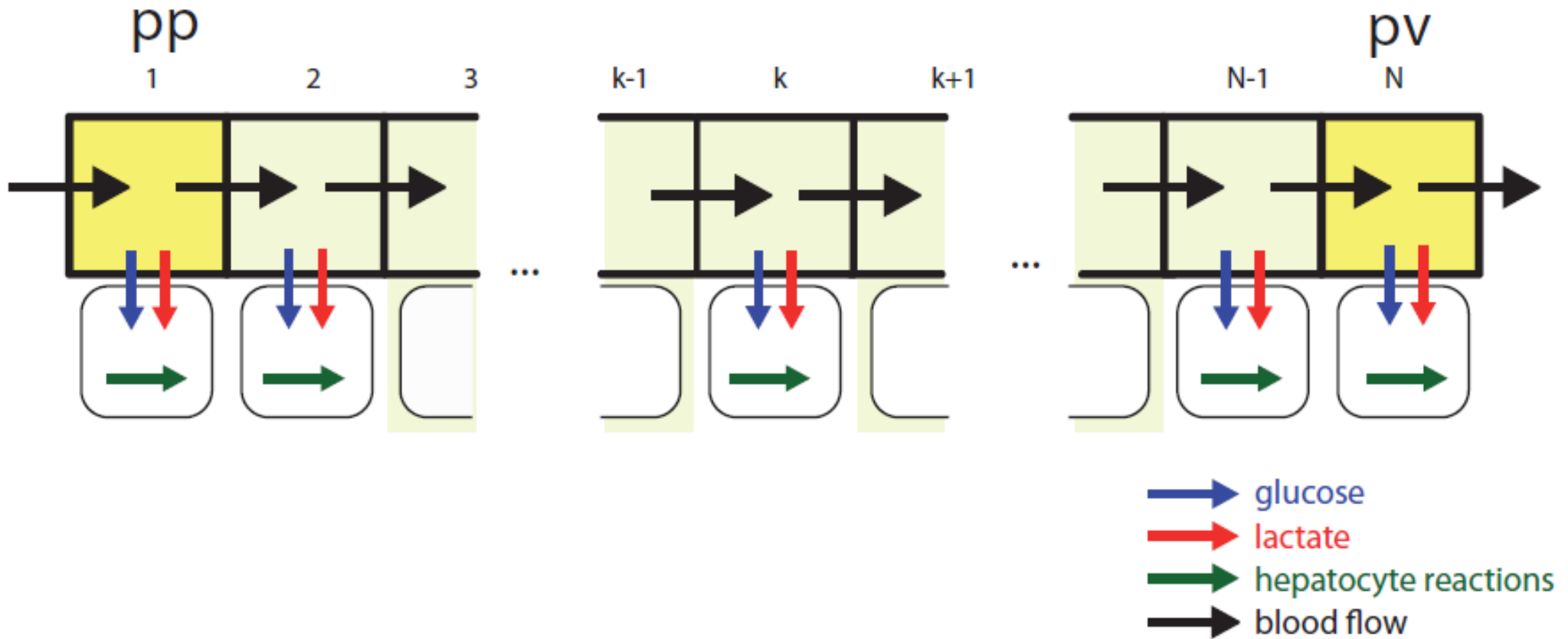

Blood flow

- Parallel sinusoids
 - diameter d_s , length L , blood velocity v , hepatocytes N , number sinusoids n

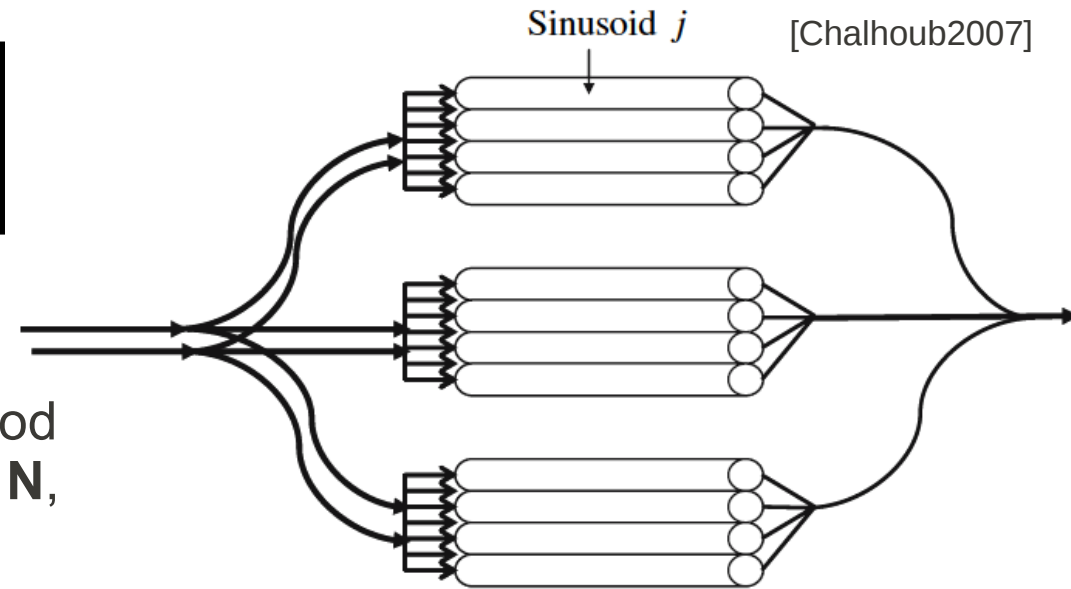

Variable	Description	Value used in model	Additional information/reference
d_s	Diameter of sinusoid	$5.7 \mu\text{m}$	$4 \mu\text{m}$ (PP) and $5 \mu\text{m}$ (PP) ⁵⁰ ; $5.9 \mu\text{m}$ (PP) and $7.3 \mu\text{m}$ (PV) in mice ⁵¹ ; $7\text{--}15 \mu\text{m}$ ⁵⁶ .
d_t	$\frac{1}{2}$ of hepatocyte sheet thickness	$5.5 \mu\text{m}$	$3.6 \mu\text{m}$ (calculated from Goresky <i>et al.</i> , ²⁶) $6\text{--}12 \mu\text{m}$ human hepatocyte radius, $2.5\text{--}8 \mu\text{m}$ in other tissue (http://www.bartleby.com/107/pages/page1196.html)
d_{ed}	Endothelial cell thickness + space of Disse	$1.8 \mu\text{m}$	Calculated from Goresky <i>et al.</i> ²⁶ .
L	Sinusoid length	1 mm	1 mm ⁵⁰ ; 0.25 mm ⁵⁶ ; 0.3 mm , estimated from images ⁵¹ .
V_{tissue}	Volume of tissue surrounding a single sinusoid	$9.5 \times 10^{-8} \text{ cm}^3$	Calculated.
V_{blood}	Volume of blood within a single sinusoid plus the space of Disse	$4.42 \times 10^{-8} \text{ cm}^3$	Calculated.
v	Velocity of blood in sinusoid	$183 \mu\text{m/s}$; yields $\tau = 5.4 \text{ s}$	Mean values: $69 \mu\text{m/s}$ (mouse) and $180 \mu\text{m/s}$ (rat), range: $0\text{--}400 \mu\text{m/s}$ ⁵¹ ; $150, 250 \mu\text{m/s}$, rat ⁴⁷
$n_{\text{sinusoids}}$	Number of sinusoids in the liver	5.23×10^9	
Q	Blood flow rate through liver	1.47 l/min	

Blood flow

- Blood compartments transported along sinusoid
 - Simplest blood model
 - Constant pp concentration of glucose and lactate for simulations
- Single packet and continuous packet tests
- Transfer time single passage ~6s

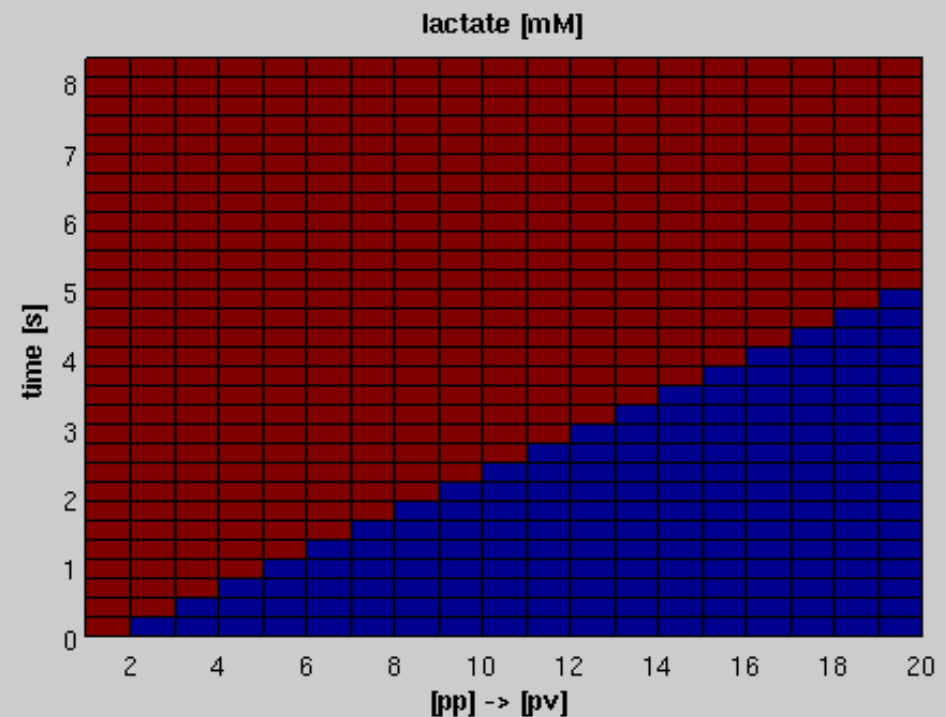
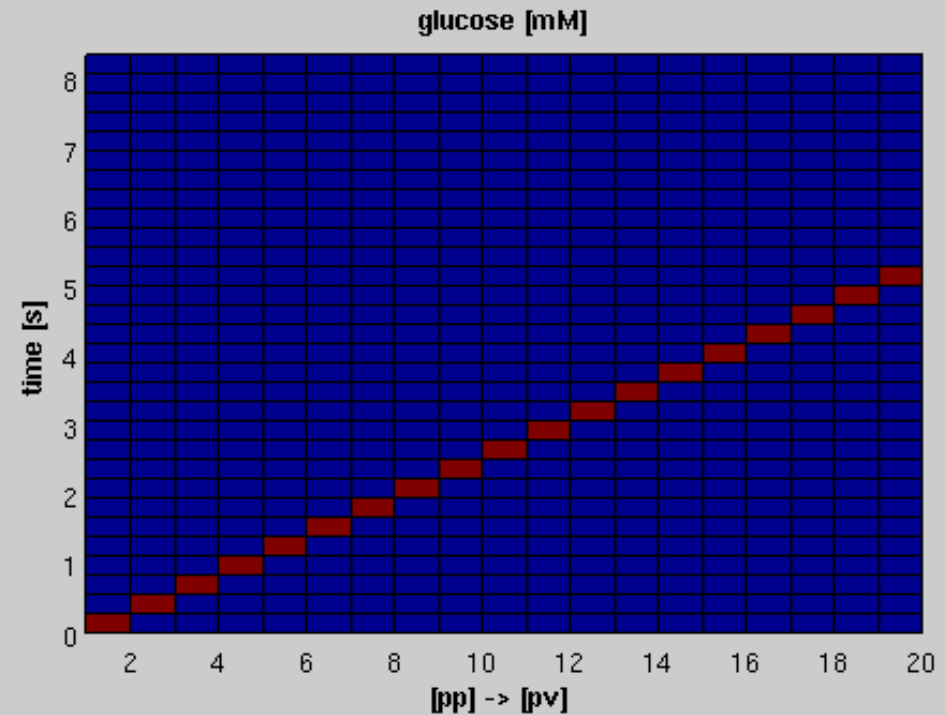

Hormone gradients

- Gradients of insulin, glucagon and epinephrine over sinusoid due to clearance
- Only cleared until basal level
- Hormone profiles determined by pp glucose concentration
 - 0.5 insulin clearance
 - 0.5 glucagon clearance
 - 0.5 epinephrine clearance

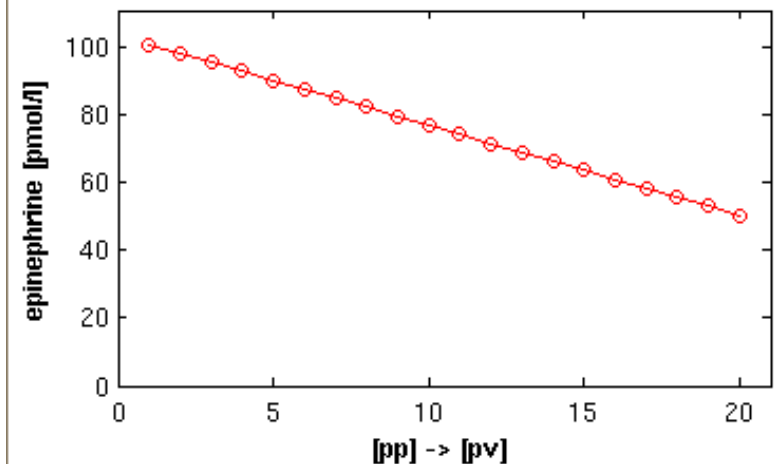
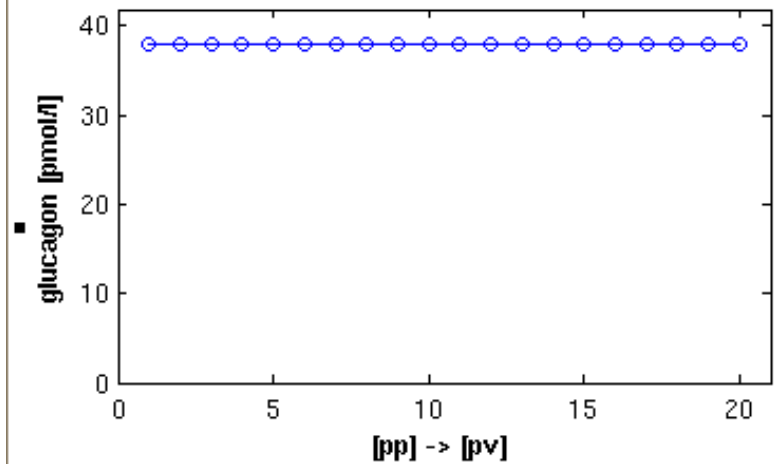
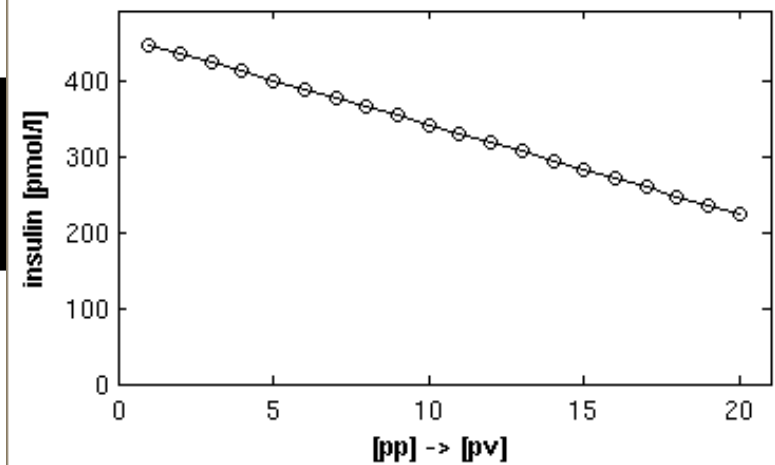

Mean hepatocyte (hypoglycemia)

- Zonated model, mean hepatocyte, hormone gradients
- Metabolite gradients due to metabolic activity of hepatocytes
- Pp glucose 3mM
- Pp lactate 5mM
- Liver main role as glucose producer

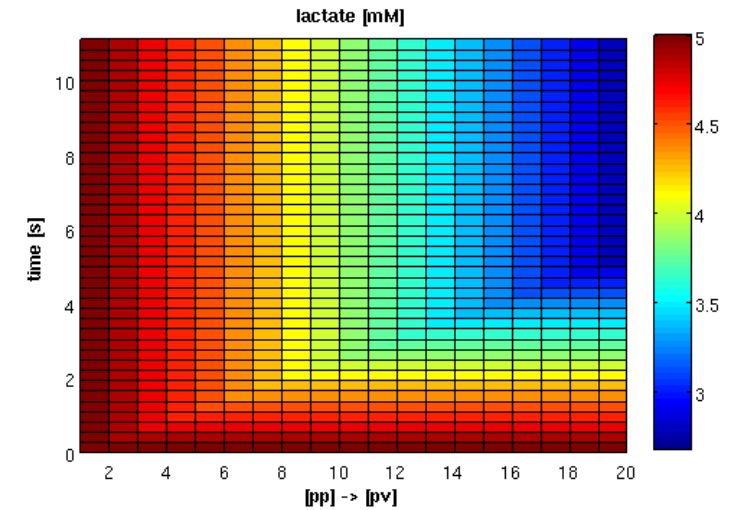
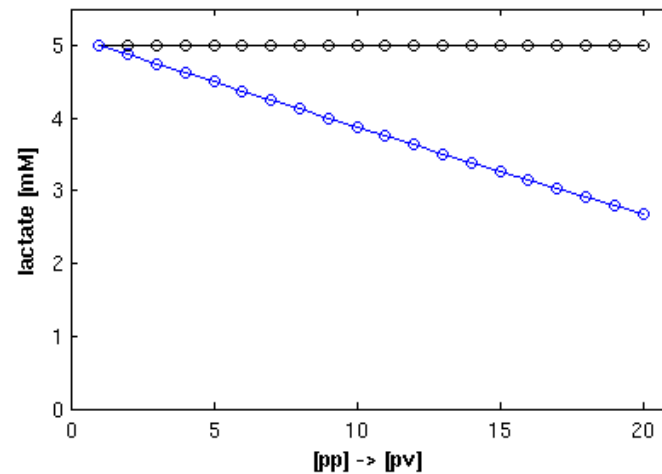
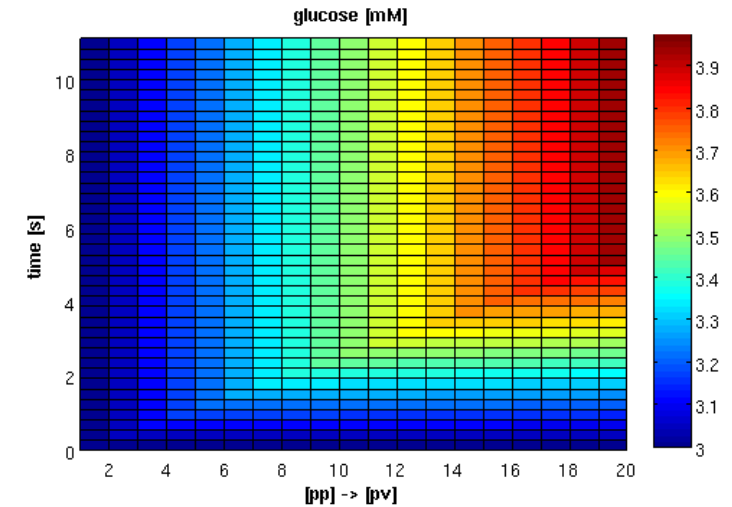
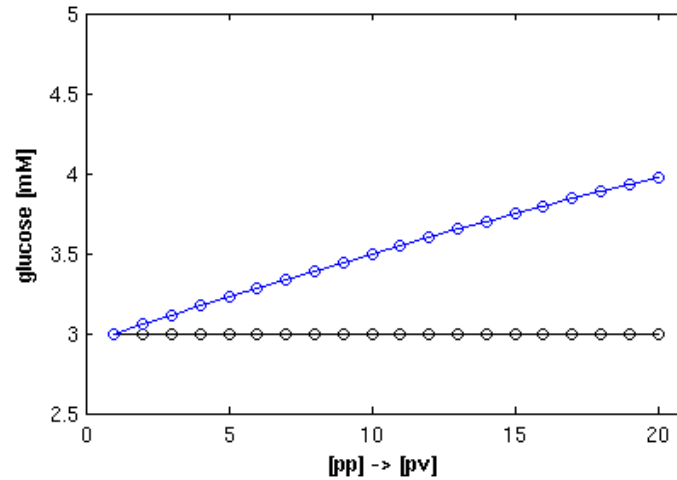

Mean hepatocyte (hyperglycemia)

- Zonated model, mean hepatocyte, hormone gradients
- Pp glucose 9mM
- Pp lactate 5mM
- Liver only moderate glucose consumer

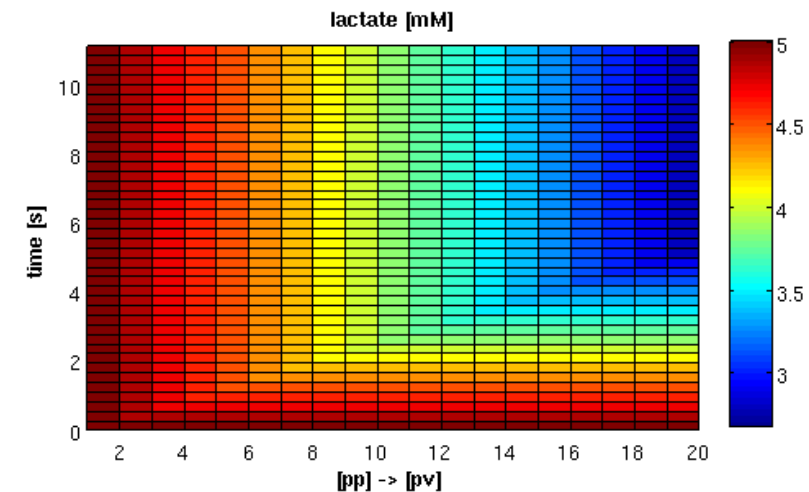
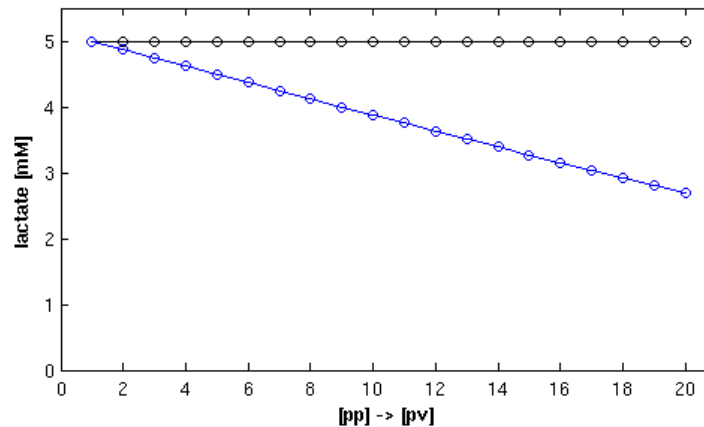
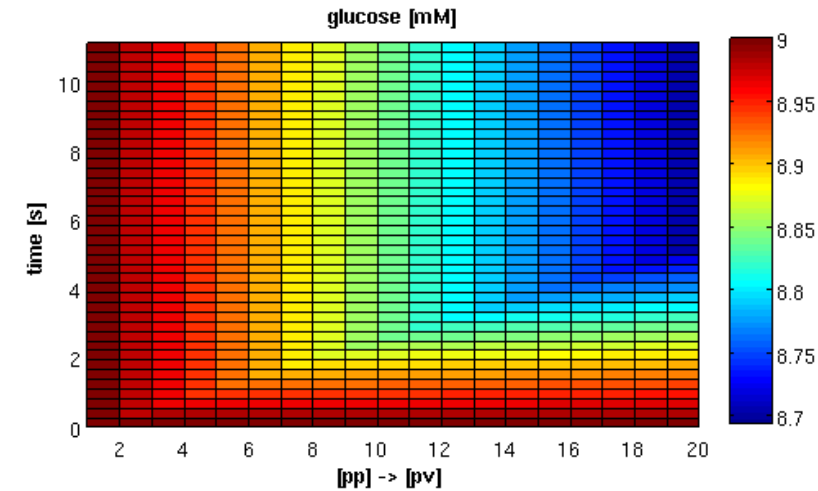
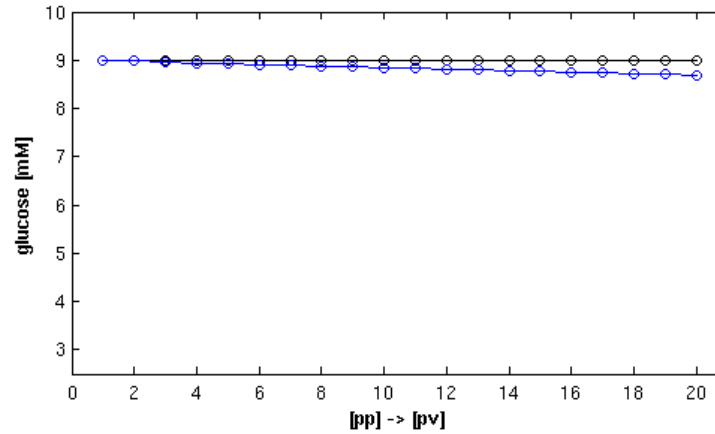

Zonated hepatocytes

- changes in V_{max} in key enzymes in accordance with observed changes in gene expression generate pp and pv hepatocytes

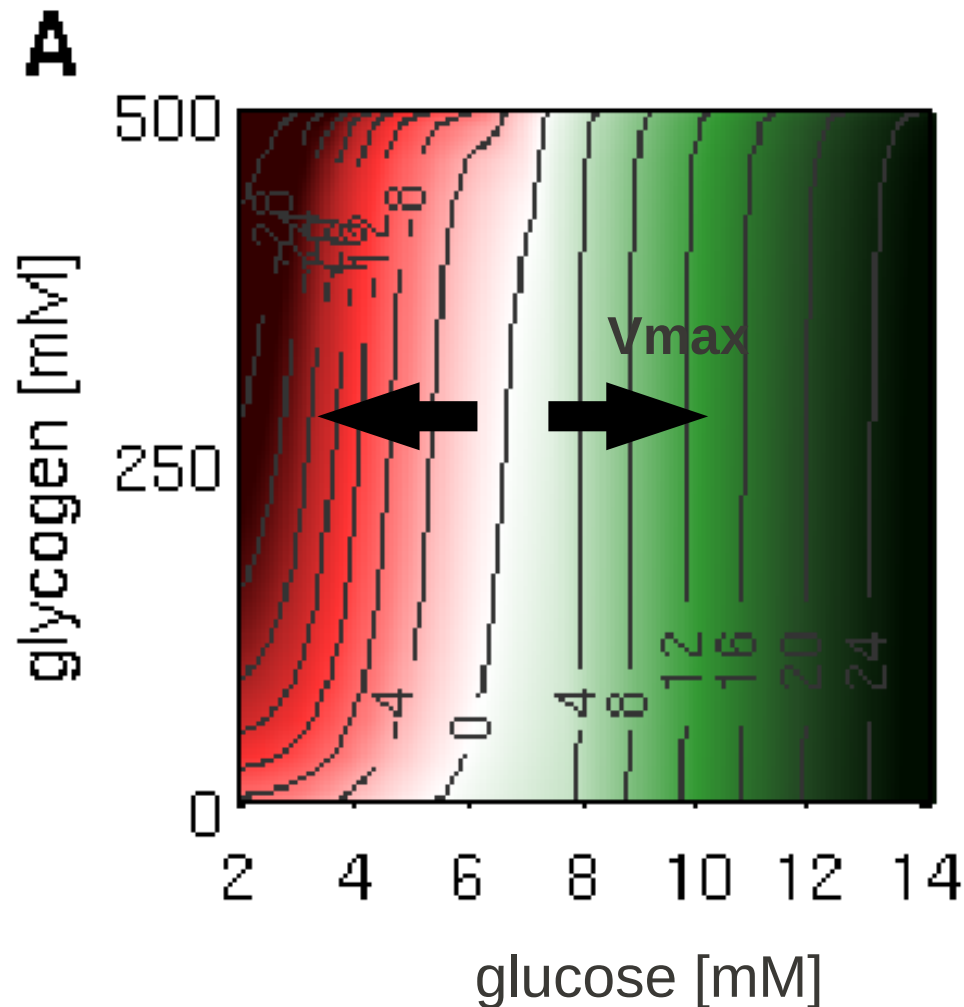

Zonated hepatocyte (hypoglycemia)

- Zonated model, zoned hepatocyte, hormone gradients
- Metabolite gradients due to metabolic activity of hepatocytes
- pp glucose 3mM
- pp lactate 5mM
- Liver main role as glucose producer

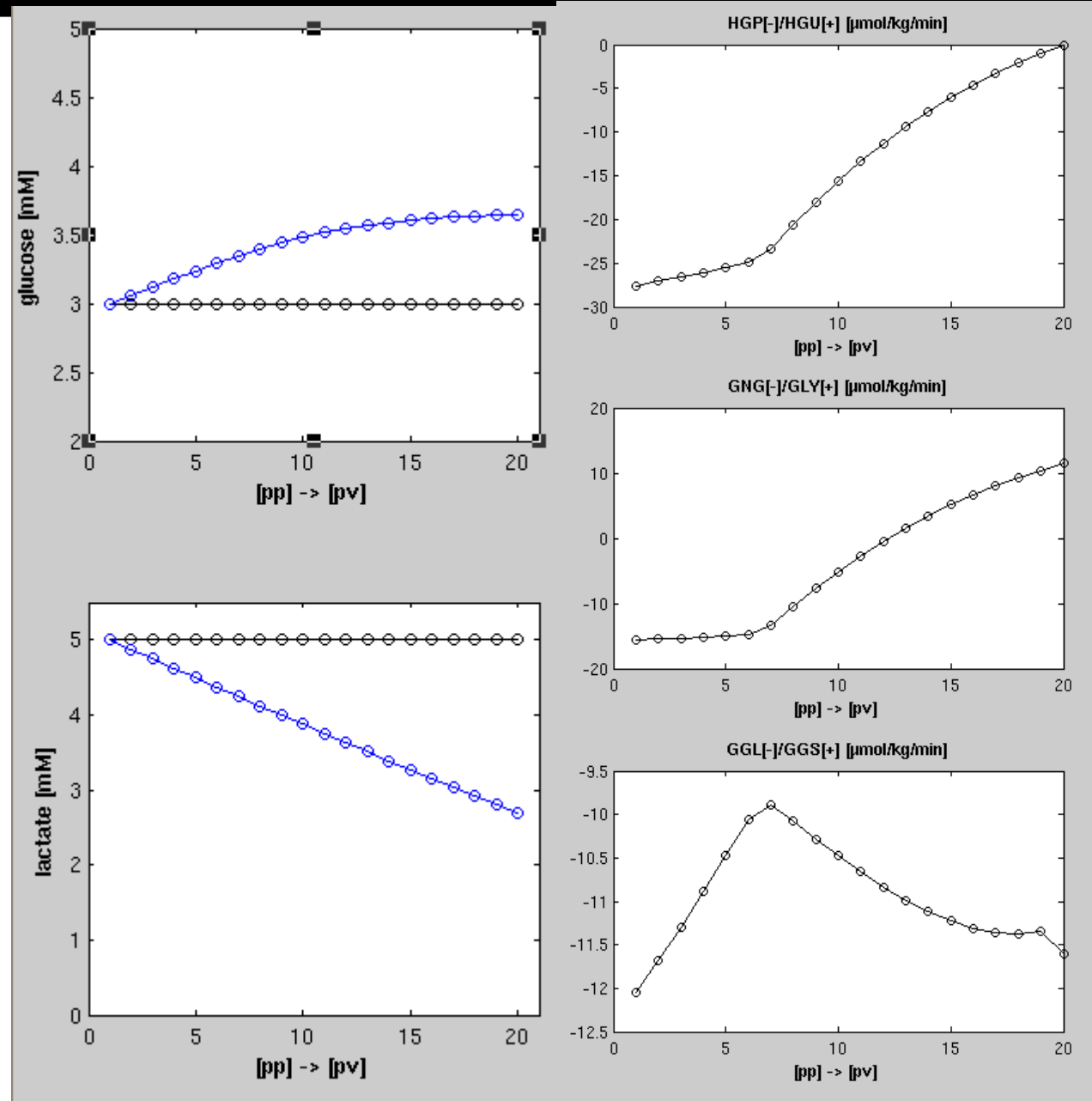

Zonated hepatocyte (normglycemia)

- Zonated model, zoned hepatocyte, hormone gradients
- pp glucose 6mM
- pp lactate 5mM
- Zonation HGP/HGU, GNG/GLY, GGS via direct and indirect pathway

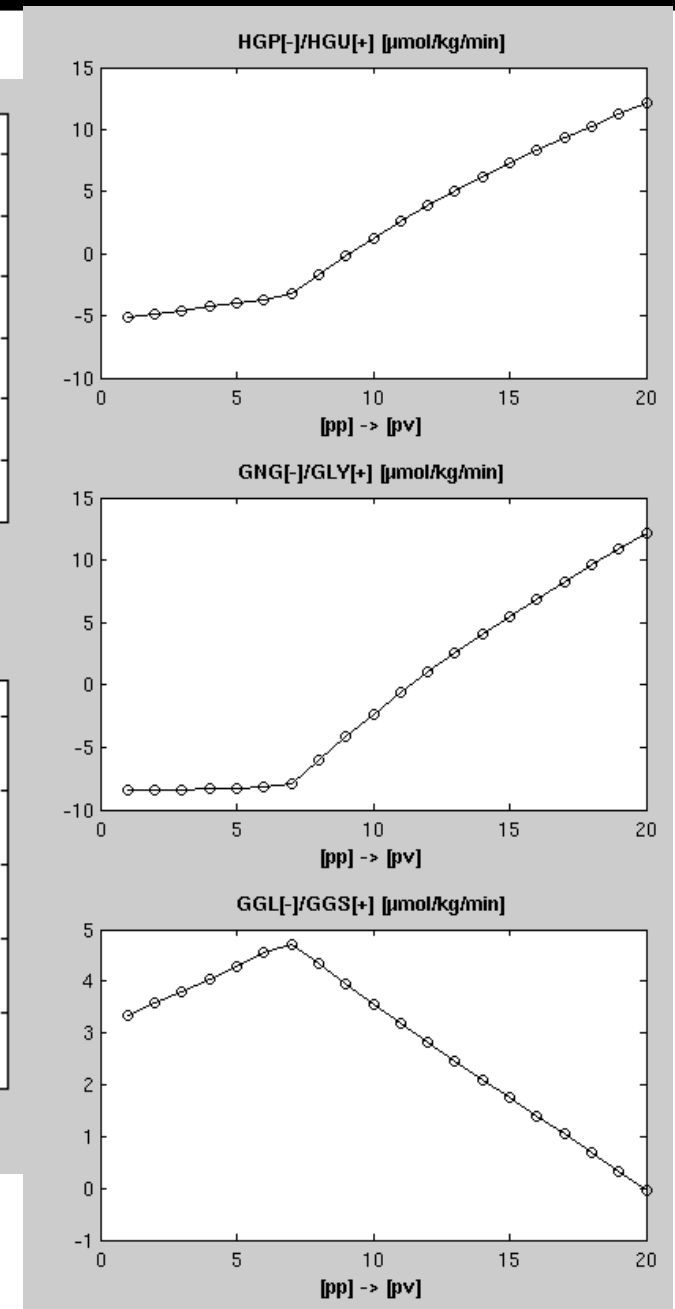
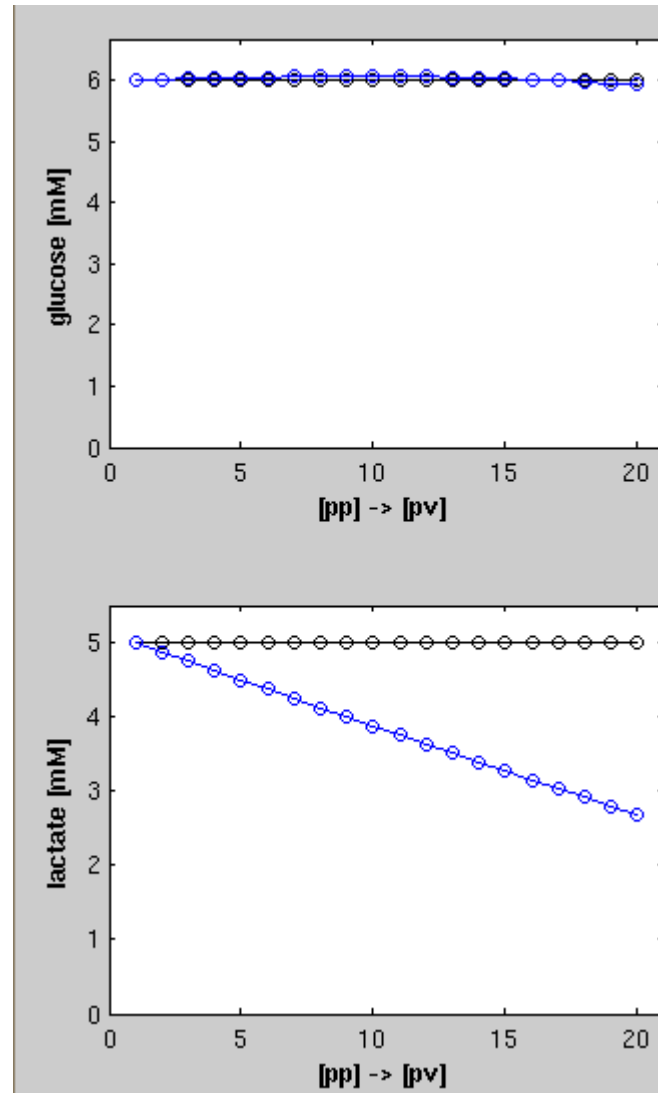

Zonated hepatocyte (hyperglycemia)

- Zonated model, zonated hepatocyte, hormone gradients
- pp glucose 9mM
- Pp lactate 3mM

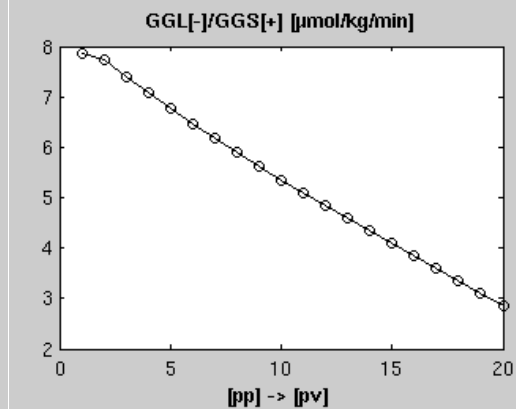
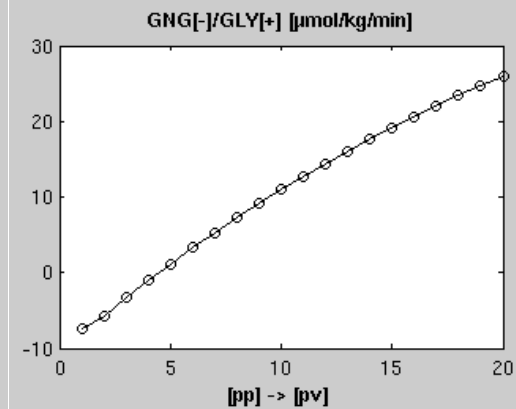
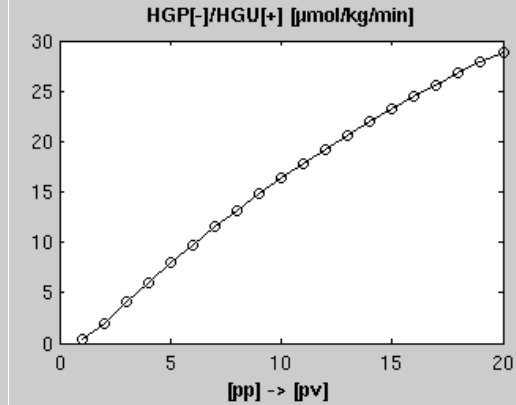
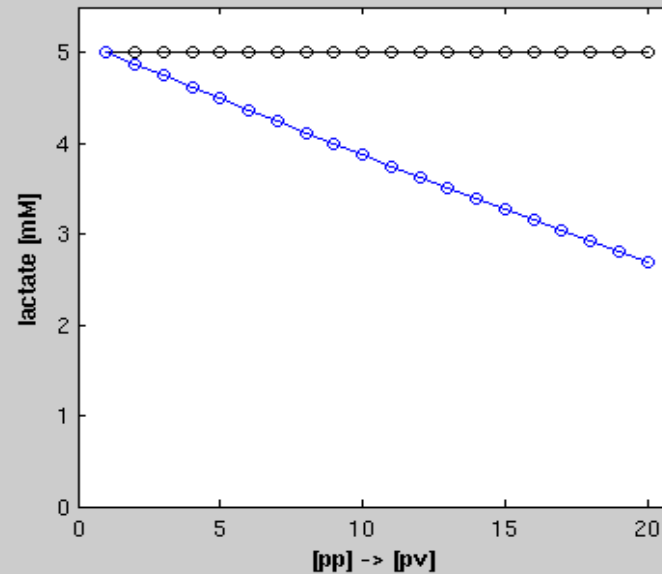
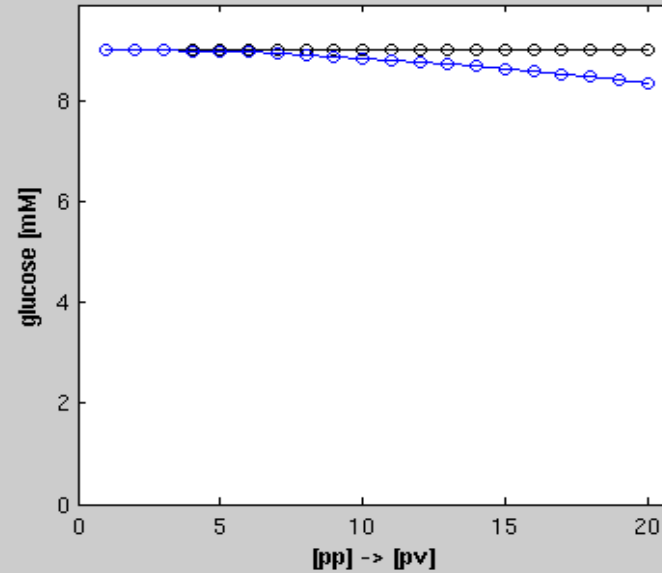

Summary

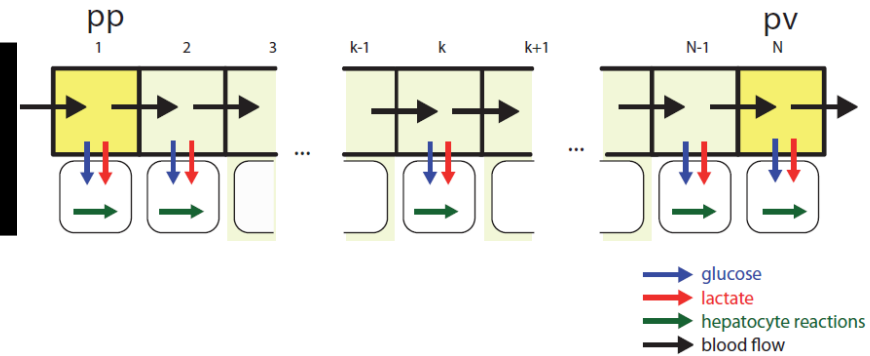

▪ Status

- first draft of zoned model
- coupling of single hepatocyte model to blood flow
- hormone gradients in combination with zonation of key enzymes (V_{max}) generate zoned glucose metabolism

▪ Next steps

- solve lactate problems
- use zoned gene expression and protein data for V_{max} changes
- more realistic blood flow model (space of Disse)
- including data from HGP/HGU liver clamp experiments and pp-pv perfusion experiments